

ECO.32+

Magnetic drilling machine

EUROBOOR

FOR PROFESSIONALS BY PROFESSIONALS

Technical data

	Metric	Imperial
Annular cutting	Ø 12 - 32 mm	Ø 1/2" - 1 1/4"
Twist drilling	Ø 1 - 13 mm	Ø 1/16" - 1/2"
Countersinking	Ø 10 - 40 mm	Ø 3/8" - 1 9/16"
Length	320 mm	12 5/8"
Width	210 mm	8 1/4"
Height	370 - 512 mm	14 9/16" - 20 3/16"
Stroke	150 mm	5 15/16"
Weight*	11 kg	24.3 lbs
Magnet (l x w x h)	160 x 80 x 42 mm	6 5/16" x 3 1/8" x 1 5/8"
Magnetic force	1,500 kg	3,305 lbs
Motor power	1,000 W	9.1 A
Total power	1,050 W	9.5 A
Speed		775 rpm
(no load)		
Speed		440 rpm
(load 1,000 W, 9.1 A)		
Spindle (Weldon)	19.05 mm	3/4"
Voltage		110 - 120 V / 60 Hz 220 - 240 V / 50 - 60 Hz

* Without power cord and handles

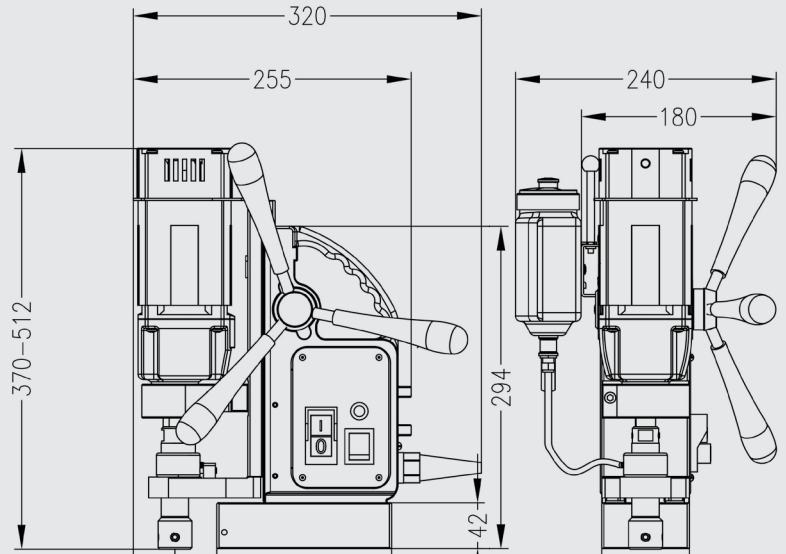

Features

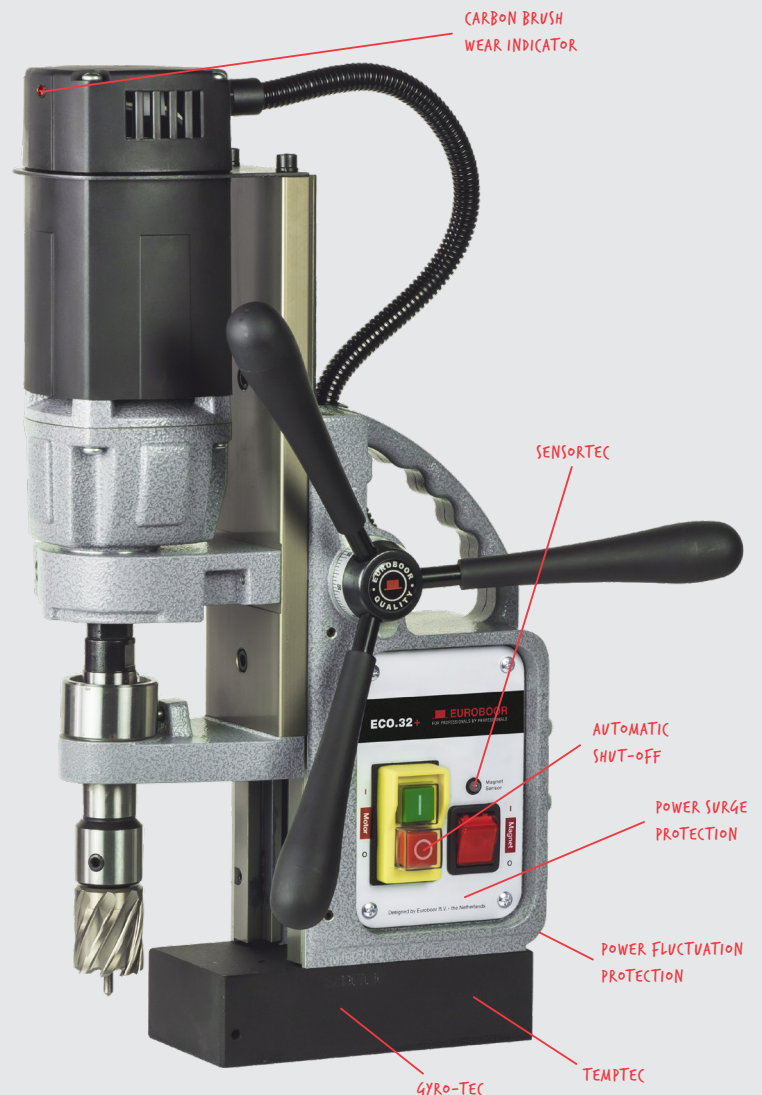
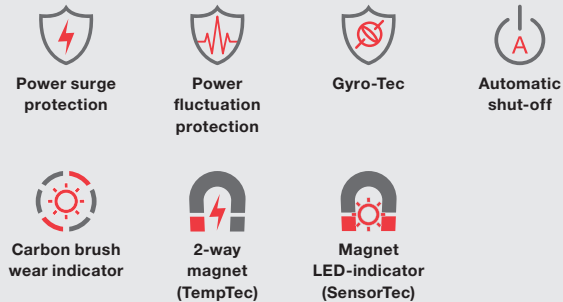

Euroboor makes every effort to meet quality and integrity requirements. That is why we as an organization are proud of the recognition of some leading organizations worldwide:



www.euroboor.com